

- 1) As we discussed in class, focused laser beams can trap particles by redirecting rays of light. In this case, we consider a perfectly transmitting sphere with an index of refraction n in air, and we'll do a simple calculation using ray optics.

Use conservation of momentum to calculate the momentum transferred to the sphere in the forward and the transverse directions. To keep things simple,

- account for reflection and refraction at the first interface, and refraction only at the second interface.
- do the calculation only for the two rays shown in the figure below. These rays are incident on the sphere at equal distances from the sphere centerline, such that the reflected rays emerge at 90° to the incident beam. Ray 1 and ray 2 have intensities I_1 and I_2 , with $I_1 > I_2$.

Use Snell's law to calculate the internal angles and assume that 4% is reflected at each interface (*even though this isn't exact*), with the rest refracted. To check numbers, you can assume the refractive index of the sphere is 1.5, outside it is 1. Note that only the incoming and outgoing wave vectors matter. Also, we want to establish the *sign* of the transverse force, relative to the intensity gradient. Don't worry about the absolute magnitude of the force – you would have to integrate over the whole sphere for that.

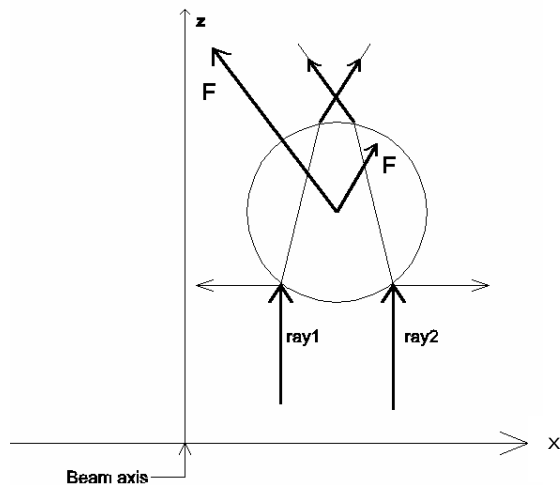

- 2) A filter to reduce the intensity of a beam can be made by evaporating a thin layer of metal, such as silver, onto a glass substrate. In the lab these are typically used to control the light level on a detector or a camera or as beamsplitters. The real and imaginary parts of the refractive index for silver for green light ($\lambda = 500\text{nm}$), are $n_R = 0.15$ and $n_I = 4.0$.
- Calculate σ and ϵ from these values of the index. Note that at this high frequency the result differs from the DC values.
 - Calculate the skin depth δ for green light incident on silver. Use the convention that the skin depth is where the *field* falls off by $1/e$ from the surface.
 - To calculate the transmission through a thin layer ($L \approx \delta$), one must in principle account for the reflection at the second metal-glass interface. But that reflected wave is attenuated on the way back, so we can to a good approximation ignore that second reflection. Assuming then

that the transmitted intensity is $I_t = I_{inc} e^{-\alpha L}$. The attenuation coefficient is $\alpha = 2\delta$ (the factor of 2 is there because we are concerned with the intensity). The “optical density” (OD) of a filter is defined as $-\log_{10}\left(\frac{I_t}{I_{inc}}\right)$. Calculate the thickness of a silver film required to make filters of 0.1, 0.5, 1.0, 2.0 and 3.0 OD (or plot the thickness vs. OD over this range).

3) HM problem 6-6.

4) A Fresnel rhomb is a prism that can be used to convert linear polarization to circular (see figure below). The input polarization is linear, with the \mathbf{E} -field vector oriented at 45° to the x -axis (i.e. equal amplitudes for E_x and E_y). If we define the amplitude reflection coefficient r through the equation $E_1^0 = rE_0^0$, we can identify the factors r_\perp and r_\parallel through equations 6.26 and 6.32 for the \perp and \parallel cases respectively. Program the Fresnel equations in Mathematica; since for TIR the values of r will be complex, you can calculate the phase through the command $\phi = \text{Arg}[r]$. Calculate and plot the phase difference $\Delta\phi(\theta)$ between \perp and \parallel to determine the angle θ shown in the figure below that the prism converts the input linear polarization to circular at the output. Do this for two refractive indices of 1.45 (fused silica) and 1.65 (flint glass). **Let the outside index be $n_0 = 1$.**

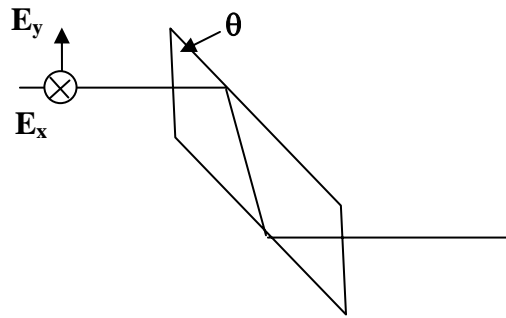

5) We can take advantage of total internal reflection and birefringence to make a high-quality polarizer. Consider the following arrangement below:

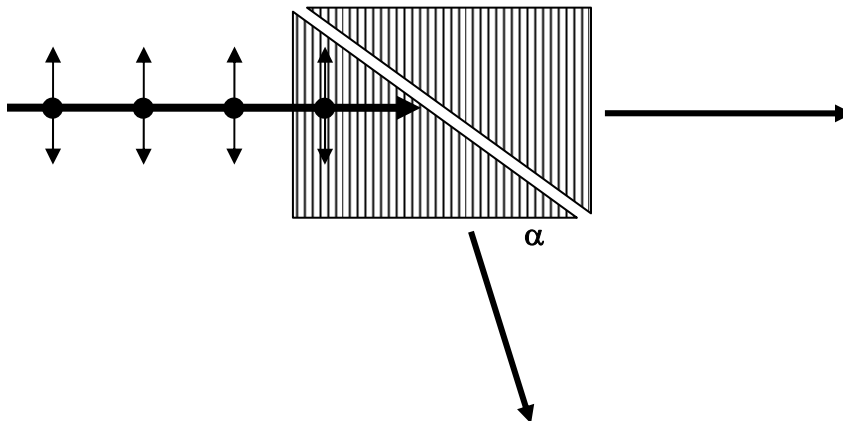

The extraordinary axis ($n_e = 1.4864$) is aligned with the lines shown, the ordinary axes has an index of $n_o=1.6584$. Find the angle α of the prism such that one polarization direction of an

unpolarized beam is totally reflected at the first diagonal interface, and the other polarization direction is totally transmitted. You may neglect any reflection losses at the outer perimeter. Make a detailed sketch of the ray path for both polarization components, calculating ray directions with Snell's law.